

Building Control

Technical Guidance Leaflet



Installing Solid Fuel Stoves

A guide to installing domestic stoves in accordance with Approved Document J – Combustion Appliances and Fuel Storage Systems. Building Regulations 2010.

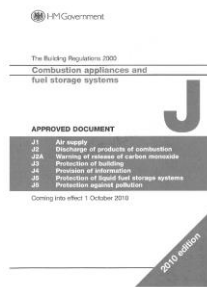

The installing of wood burning and multi fuel stoves is work that is controlled under the Building Regulations as is the relining or installation of flues and chimneys associated with such heat producing appliances. This means that it is usually necessary for a house owner to submit an application to Building Control before starting work. The following pages contain a brief description of the building regulations that apply. You can find out more detailed information in Approved Document J of the Building Regulations 2010 and you can download this document from the planning portal at www.planningportal.gov.uk . The Building Control section at your local council will also be able to give you any further advice you may need.

Although qualifications are not mandatory, any person fitting a solid fuel stove must be competent to do so i.e. familiar with the correct procedures and associated regulatory requirements.

INDEX

Page	Subject
2	Competent Person Schemes Applications to Building Control
3	Connecting to existing chimneys Re lining chimneys Stove flue sizes New masonry chimneys
4	Single wall flue pipes
5	Factory Made metal chimneys Outlets from flues pipes and chimneys
6	Hearths
7	Ventilation of stoves Positioning ventilation for a stove
8	Notice Plates
9/10	Carbon Monoxide Alarms Commissioning checklist Planning Permission Smoke Control Areas Other information



Competent Persons Schemes

Some installing companies are registered with a government approved 'competent persons scheme' that enables them to self certify their own work as compliant with the relevant regulations. If you choose to have your stove installed by such a company then you will not need to submit an application to Building Control. The most common scheme provider for such works is HETAS (www.hetas.co.uk). Make sure that the installer is listed as registered and leaves you a certificate of compliance at the end of the job.

Applications to Building Control

For other installations it is necessary for a house owner to make an application for Building Regulations permission. This involves filling in an application form, sending it with the necessary fee and details of the installation to your local council. A 'Full Plans' application needs to include full details and specifications of the stove and associated information to demonstrate compliance. You may alternatively make a 'Building Notice' submission. With a Building Notice it is not essential that you include all details and specifications although Building Control may request these. A disadvantage of using a Building Notice is that the installer will not have approved specifications to work to. This can cause problems when Building Control later inspects the work. Relevant forms and fee information are available from your local council website or from the local council offices.

When you start work following approval of your application you are legally obliged to notify the council. A Building Control Surveyor or Technical Officer will inspect the works to ensure compliance and on satisfactory completion you will receive a certificate confirming that they are satisfied that the work complies. This is an important document should you later decide to sell your property.

Connecting to Existing Chimneys

An existing chimney must be given a visual inspection to check that it is in good order, clear of obstructions such as dislodged masonry or bird's nests and it is of suitable size and type for the appliance you intend to install (see below). It will probably be necessary to sweep the flue which should always be done anyway before fitting a stove or lining a chimney. Old chimneys are often very inefficient and particularly if unlined, can leak products of combustion and tars through the chimney walls. It is quite common to find that old chimneys are in poor condition due to the flue surface and mortar joints being eaten away by corrosive condensates and soot deposits. It was only in 1965 that the Building Regulations required that all chimneys had to be built with suitable flue liners of the correct flue size to protect the chimney structure.

It is therefore very wise to have any old chimney you are using checked for its condition and particularly if you are planning to re-open an old chimney after many years of not being used. A smoke test should be carried out to establish whether there is a major fault that can cause products of combustions to leak through the chimney walls. The general condition of the chimney in terms of structural stability should also be checked, as well as making sure it is wind and water tight.

Re Lining Chimneys

Carrying out the above checks should identify any repair work that is needed and it is often necessary to have a chimney fitted with a new liner, which should improve both performance and safety. There are many factory made relining systems available made from clay, ceramics or refractory concrete consisting of pumice or kiln burnt aggregate bonded with high alumina cement. These liners are simply lowered down the chimney on guide ropes with locating bands at the joints. The gap between the liners and chimney is then backfilled with an insulating lightweight concrete. Whilst this type of lining offers a long life, the existing flue opening has to be large enough for the correct sized liners to be installed and it is necessary to open up the chimney to install bends causing disruption and the need to make good and redecorate.

Re lining with steel is an alternative method with advantages and disadvantages. Not to be confused with single skin liners for gas, multi fuel flexible liners are double skinned and made from an extremely high quality stainless steel, usually 904L or 316Ti (titanium) grade. They are smooth on the inside, corrugated on the outside and must be installed the correct way up. They are simply lowered down or pulled up the chimney and can go around most bends their slim profile enabling quick installation into chimneys where other systems might not easily fit. Their life can be reduced if abnormally high corrosive soot and condensate deposits are created and allowed to accumulate in the flue or have not been thoroughly removed from the walls of the existing chimney flue. The backfilling of the steel liner is not particularly mentioned in Approved Document J but it is a good idea for efficient operation and a good 'chimney draw'.

Other re lining systems available include the use of pumped refractory concrete, spray on linings and ceramic coatings. Always check with HETAS or Building Control that such systems are regulations compliant.

Stove flue sizes

The flue size (diameter or cross sectional area) must be no smaller than the size of the stove outlet.

Building Regulation require that the minimum flue size for stoves is as follows:

Up to 20kW burning smokeless fuel – Minimum of 125mm diameter.

Up to 30kW burning any fuel – Minimum 150mm diameter.

In the long term it is difficult to control the type of fuel that may be burned so we would strongly recommend that 150mm is the minimum size used.

If rectangular or square flues are used then they should have an equivalent cross sectional area and a minimum dimension of 100mm for straight flues and 125mm for flues with bends.

New masonry chimneys

These can be divided into two categories:

- 1) Conventional brick or masonry with either clay/ceramic liners certified to BS EN 1457 or refractory concrete flue liners to BS EN 1857. To form a chimney, the liners have to be surrounded with at least 100mm thick brick, block or stonework with the gap in between filled with insulating concrete i.e leca, vermiculite or perlite (unless manufacturers guidelines specify otherwise).
- 2) Prefabricated chimney block systems certified to BS EN 1858 comprise an inner liner of concrete or clay/ceramic as specified above and an outer block of insulating concrete. Chimney blocks are designed to be used as a unit and can normally accommodate a range of appliances.

New masonry chimneys should be constructed with flue liners and components that are suitable for the stove being fitted. The steel products used for re lining are not acceptable in new chimneys. Manufacturers installation instructions must be closely followed.

New chimneys need to be constructed off suitable foundations. They should incorporate a damp proof course above ground level and appropriate weathering where passing through the roof. Further information on the latter can be found on the Lead Sheet Association’s website at www.leadsheetassociation.org.uk . It is essential that adequate clearance is maintained from combustible material and this is indicated in the diagram below. Combustible material other than skirting boards such as joists, floor boards and rafters must be at least 40mm from the chimney masonry or 200mm from the inner surface of the flue.

Diagram 1 – Chimneys – Separation from combustible materials

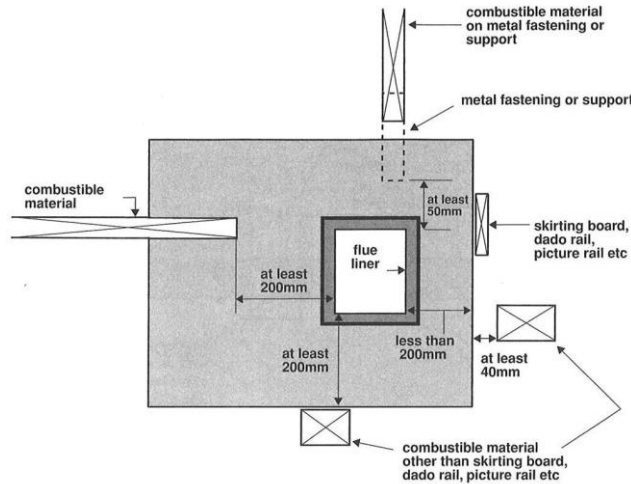

Single Wall flue pipes

Single wall enamelled steel pipes are traditionally used to connect the stove to the chimney system. They must be at least three times their diameter from combustible materials. For example a 150mm single skin flue pipe must be at least 450mm from combustible materials (in fact the actual figure is a little higher as this clearance is based on external diameters). The combustible material can be heat shielded in which case the flue must be at least 1.5 times it’s external diameter away from the heat shield, the heat shield must extend at least 1.5 times the flue’s external diameter to each side of the flue, and there has to be an air gap of at least 12mm between the shielding material and the combustible material. Cement based fire protection boards can be used for this purpose.

Diagram 2 – Single skin flue pipes – clearance from combustible materials

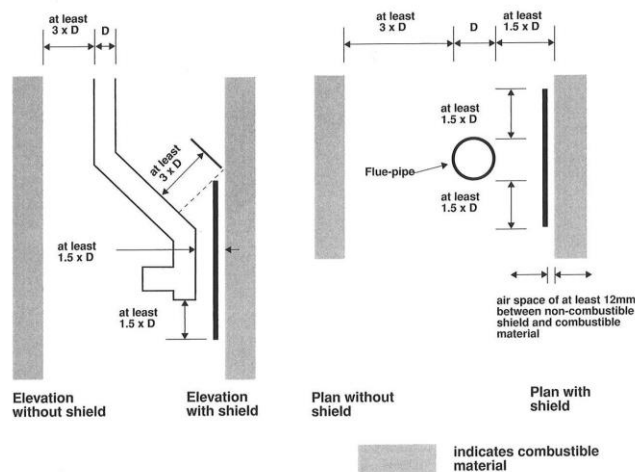

Shields should either:
 a) extend beyond the fluepipe by at least 1.5 X D; or
 b) make any path between fluepipes and combustible material at least 3 X D long

Whilst there is currently no maximum or minimum length specified for a single skin flue pipe that connects a stove to a chimney, it is not permitted to extend beyond the room containing the stove. The length is best kept to a minimum as heat will transfer to the room from the uninsulated flue pipe. This leaves the flue gases colder which reduces the ‘draw’ allowing a faster accumulation of soot and tar deposits in the chimney.

Factory Made Metal Chimneys

These systems are used as an alternative to masonry chimneys and consist of interlocking sections with a stainless steel outer casing surrounding high performance insulation and a flue liner made of stainless steel. Some systems have a ceramic or refractory concrete flue liner which offers better resistance to corrosion. Products must meet the requirements of BS EN 1856-1:2009. The metal lined systems should give a normal life of 10 – 15 years or more when correctly installed, operated and maintained. However, prolonged periods of slow burning particularly using solid fuels, combined with inadequate cleaning of the flue can cause corrosion damage which may reduce the expected life of the liner.

Liners should have a designation of T400 N1 D Vm L40040 Gxx where L40040 is the minimum material specification in the National Annex to BS EN 1856-1 and xx is the necessary separation from combustible materials in millimetres. As for other systems, the manufacturer's installation instructions must be strictly adhered to ensuring adequate support and provision for expansion. There must be access via inspection hatches at least 300mm square to enable commissioning and maintenance checks to confirm that the flue is continuous, all joints are correctly assembled and gas tight and the flue is adequately supported.

Where passing through a cupboard, room or roof space the metal chimney must be guarded to prevent any combustible material coming to within xx separation distance mentioned above. Where passing through a floor, manufacturers supply fire stop components to space the chimney from the timber and maintain fire resistance of the floor. These are usually of the ventilated type however unventilated components are available giving a level of safety from smoke penetration to the room above should a fire occur.

Outlets from Flues and Chimneys

The flue gases from the stove must be able to discharge freely without presenting a fire or health hazard, whatever the wind conditions. To get a good chimney draw the flue outlet needs to be positioned above the zones over the roof surface and around buildings where wind eddies and down drafts can occur. The approved Document gives comprehensive guidance on how this can be achieved. Diagram 3 below illustrates the safe zones for flue outlets in relation to tiled or slated roofs with no factors that may increase wind currents.

Diagram 3 – Flue Outlet Positions – Normal Roofing Materials and Normal Circumstances

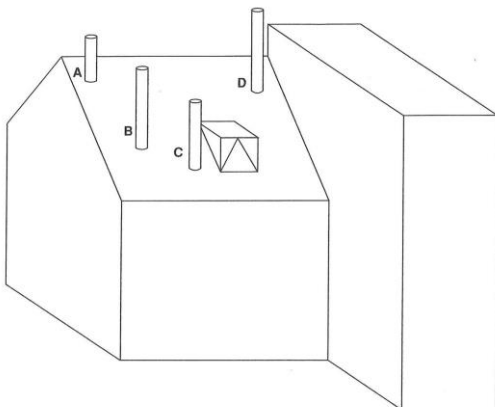

Point where flue passes through weather surface (Notes 1, 2)		Clearances to flue outlet
A	at or within 600mm of the ridge.	at least 600mm above the ridge.
B	elsewhere on a roof (whether pitched or flat)	at least 2300mm horizontally from the nearest point on the weather surface and: a) at least 1000mm above the highest point of intersection of the chimney and the weather surface; or b) at least as high as the ridge.
C	below (on a pitched roof) or within 2300mm horizontally to an openable rooflight, dormer window or other opening. (Note 3)	at least 1000mm above the top of the opening.
D	within 2300mm of an adjoining or adjacent building, whether or not beyond the boundary. (Note 3)	at least 600mm above the adjacent building.
Notes 1) The weather surface is the building external surface, such as its roof, tiles or external walls 2) A flat roof has a pitch less than 10° 3) The clearances given for A or B, as appropriate, will also apply.		

- 4) For the purposes of Diagram 3 the outlet position is measured to the point of discharge or 150mm above the insulation whichever is the greater
- 5) For roofs covered with combustible material like shingles that are easily ignited the Approved Document gives guidance on the larger clearances that are necessary
- 6) The dimensions stated may need to be increased to deal with the effects on air currents of higher wind exposure, adjacent to tall buildings, high trees or high ground. In other words conformance with the recommendations does not guaranteed that the requirements will be met.

Hearths for Stoves

The purpose of the hearth is to provide a slab of non-combustible material for the stove to stand on that protects any combustible materials underneath and around from the heat of the stove and from any burning fuel that might accidentally fall out of it. The perimeter of the hearth should be clearly defined – This can be achieved using a raised edge or by raising the level of the hearth in relation to the floor.

Diagram 4 – Hearth

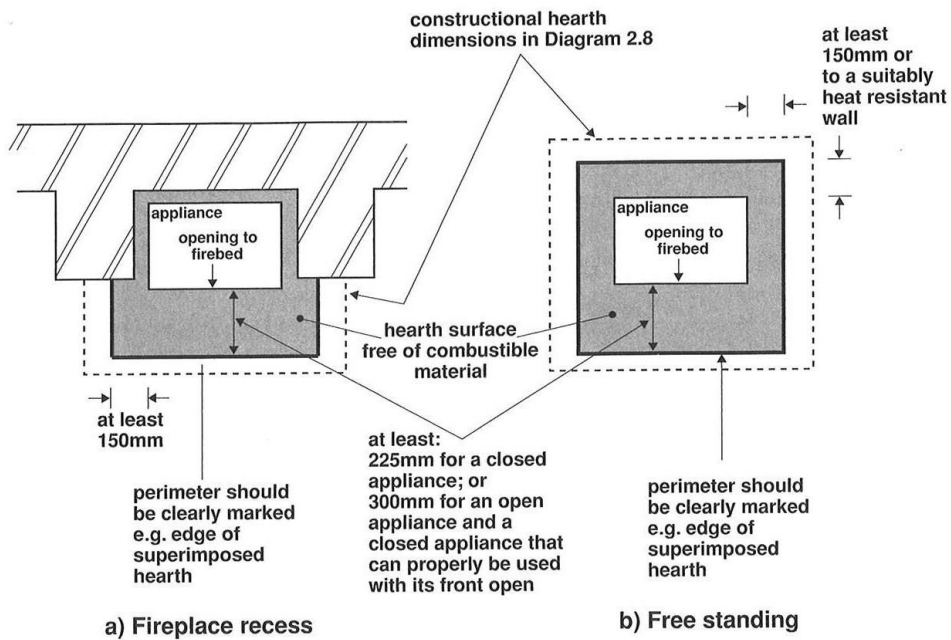

The stove must sit on a hearth extending a minimum of 150mm (6") out from the stove at the sides and 300mm (12") in front. Theoretically the frontal distance can be reduced to 225mm (9") if the stove is not designed to run with the door open. As most stoves can run with the door open the 300mm dimension should be used in most cases. The minimum size for a hearth for a freestanding stove (not in a recess) is 840 x 840mm.

Diagram 5 – Hearth Thickness

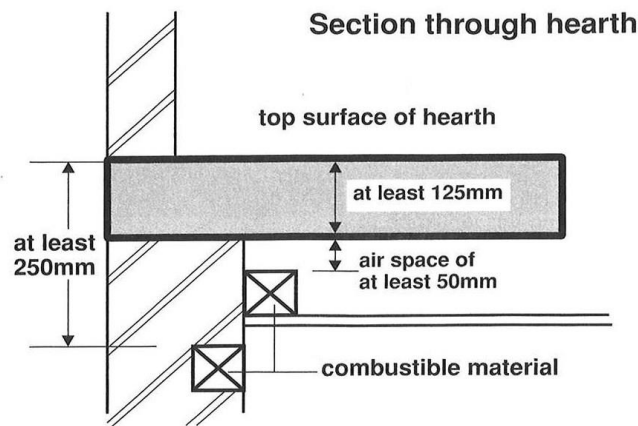

If the hearth is on a combustible floor it must be at least 250mm thick. This is reduced to 125mm if there is a 50mm air gap underneath (as diagram 5).

If the hearth is on a solid concrete floor slab or pre cast beam and block type floor then the total thickness of the hearth and floor must be 125mm. Combustible insulation should not be placed under this or the total thickness should be increased to 250mm. In all cases above, if a stove has been tested and shown to raise the temperature to over 100 degrees centigrade then a 12mm hearth may be used.

Ventilation for stoves

A very important part of installing a stove is ensuring that there is a permanent source of air to enable the combustion process to take place efficiently and safely. Without an air supply stoves are harder to light and can emit smoke into the room. A good chimney draw is reliant on there being a ready supply of air to make up the volume that passes up the chimney with the products of combustion. In extreme circumstances where ventilation is inadequate, incomplete combustion can result in carbon monoxide production due to depletion of oxygen. If this highly toxic colourless and odourless gas accumulates in a room it can lead to serious health risks that are potentially fatal. (see CO alarms below)

In recognition of this Approved Document J lays down stringent standards for providing a permanent combustion air supply to the room containing the stove. They are varied to suit the type of house and the appliance's rated output. Recent building regulations standards for energy efficiency have resulted in buildings becoming more airtight to prevent uncontrolled loss of heat. Such properties need additional ventilation as they can not rely on natural air leakage as can the majority of older properties.

Table 1 – Air supply for Stoves

Stove with a draught stabiliser fitted	<p><u>Air permeability > 5.0m³/h.m²</u> 300mm² for each kW up to 5kW 850mm² for each kW thereafter</p> <p><u>Air permeability < 5.0m³/h.m²</u> 850mm² for each kW</p>
Stove with no draught stabiliser fitted	<p><u>Air permeability > 5.0m³/h.m²</u> 550mm² for each kW above 5kW 850mm² for each kW thereafter</p> <p><u>Air permeability < 5.0m³/h.m²</u> 550mm² for each kW</p>

A house built before 2006 is unlikely to have an air permeability of less than 5.0m³/h.m² unless it has had a lot of work done to it (eg double glazing throughout, draughtproofing to doors and letterboxes etc.). A house built after 2006 is likely to have an air permeability test result and may be with the purchase documents for the house.

Some stoves have provisions for drawing outside air directly in through a duct. Otherwise the vent should be placed in such a way that it cannot be easily blocked and so that the house residents are not tempted to block it off to reduce draughts or noise. If the vent is close to the stove then draughts are reduced and the room feels warmer. The vent areas in the table relate to 'free area' and not simply the cross sectional area of the brick or louvered cowl fitted. These products are usually simply stamped with the free area that they can provide but as a guide a single 215 x 65mm plastic air brick provides around 6,000mm². Equal sized clay air bricks give as little as 1,300mm². If there is a mesh to guard against pest/mice etc. coming through the vent then the mesh size must no less than 5mm.

Positioning Ventilation for a Stove

The vent can be placed in the walls, ceiling or floor of the room. As illustrated in Diagram 6 it does not have to be in the same room as the stove, i.e. ventilation can be provided to another room which itself has permanent ventilation to the outside. A well ventilated roof space or under floor void can provide a convenient source from which to draw a supply of combustion air.

Proprietary vents are available (see Diagram 7) that can be installed using a 125mm core drill. They incorporate a series of baffles inside the duct to reduce wind noise etc..

Diagram 6 – Vent positions

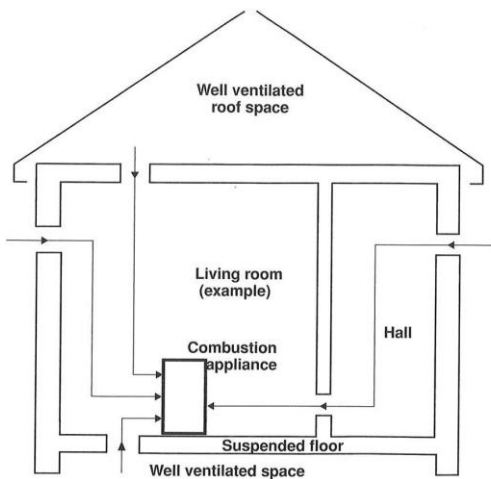
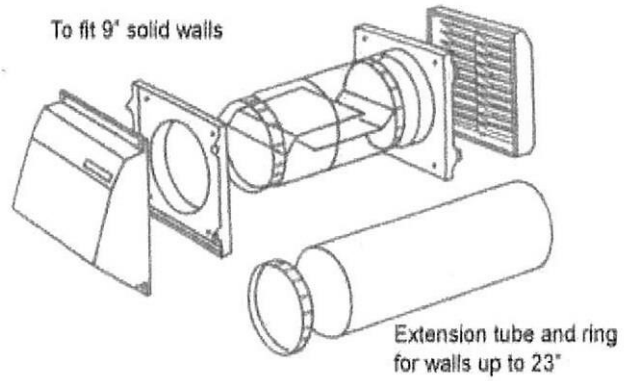

Diagram 7 – Proprietary Stove Vent System



Notice Plates

When a new or replacement hearth, flue or chimney is constructed or extended or a flue is re lined, the regulations require that a notice plate is fitted giving information essential to the correct application and use of these facilities. This must be permanently posted in the building in a location such as:

- 1) by the electricity consumer unit
- 2) by the water stop-cock
- 3) by the hearth or flue that it describes

The notice plate shows the position of the hearth and/or flue and gives essential information about materials used such as the manufacturer and flue diameter.

Diagram 8 – Example notice plate for hearths and flues

Essential information	IMPORTANT SAFETY INFORMATION	
	This label must not be removed or covered	
	Property address	20 Main Street New Town
	The hearth and chimney installed in the	lounge
	are suitable for	decorative fuel effect gas fire
	Chimney liner	double skin stainless steel flexible, 200mm diameter
	Suitable for condensing appliance	no
	Installed on	date
Optional additional information	Other information (optional)	Designation of stainless steel liner stated by manufacturer to be T450 N2 S D 3
	<i>e.g. installer's name, product trade names, installation and maintenance advice, European chimney product designations, warnings on performance limitations of imitation elements e.g. false hearths.</i>	

Carbon Monoxide Alarms

It is now mandatory to install a carbon monoxide alarm complying to BS EN 50291:2001 in rooms containing solid fuel combustion appliances. These devices are usually battery powered and have an alarm to alert users when the working life of the detector is due to pass.

Alarms should be in the same room and within 1 to 3 metres of the appliance and either;

On the ceiling at least 300mm from any wall or;

On a wall as high up as possible (Above doors and windows) but at least 150mm from the ceiling

Always follow the manufacturers installation instructions. The provision of an alarm is not a substitute for regular servicing of the stove and the flue.

Commissioning Checklist

Installers should provide Building Control with a commissioning checklist (Approved Document J – Appendix A) following installation of a solid fuel stove and/or a new chimney or chimney lining. The following associated tests need to be carried out:

- Visual Inspection
- Coring ball
- Smoke Test
- Flue/appliance spillage test

Modular or Artificial Fireplaces

In recent years, there have been several instances where heavy stone components forming part of a modern fireplace surround have become detached and fallen. This has resulted in the deaths of two young children in separate incidents. In both cases the fireplace surrounds had been installed and in use for only a matter of months before the fatal accidents.

Modular stone, or artificial stone, fireplaces have many individual components that are assembled to form the fireplace surround. Typically, they are set on top of a solid hearth, with either mortar or another bonding material acting as bedding between the stone components. Mechanical fixings (e.g. steel brackets, dowels and screws etc) are used to hold the components in position and secure them to the wall. Many of the stone pieces can exceed 50kg in weight and the mantel shelf may also have a significant overhang that projects forward of the lintel.

The Stone Federation of Great Britain has published a Best Practice Guide *Fireplace Surrounds*, to advise on the proper and safe installation of stone fireplaces. This can be downloaded free-of-charge from the **Stone Federation website**. The Guide recommends that mechanical fixings are used to restrain stone fireplace surrounds, rather than adhesives, which are not considered sufficient to provide a safe and secure bond throughout the lifetime of the fireplace surround.

Each stone forming the fireplace must have proper fixings to hold the stone in position against the wall. If the individual components aren't designed to incorporate or include adequate fixings, or if they are not installed correctly – i.e mechanically secured together and properly secured to the surrounding wall – it is possible for the mantel shelf to detach and topple over. This can be triggered by passive weight such as heavy items stored on the mantel or by a person pulling down or hanging from the projecting edge of the mantel as a child might do.

These concerns have prompted the Health and Safety Executive (HSE) to alert designers, manufacturers, installers and suppliers to the risks, and the actions they should take.

Designers, Manufacturers and Suppliers and Installers Guidelines

Designers need to make sure their design incorporates or includes fixings or fixing kits that are suitable for a range of locations and can be installed onto a variety of floor and wall types. This may include dense and lightweight masonry and timber frame.

Manufacturers and Suppliers should make sure adequate information is provided to installers so that they can safely assemble and install the fireplace surround, including:

- The fire surround is suitable for the wall and floor that it sits on ;
- How the fireplace is to be assembled including the sequence;
- Proper use of bonding products and their suitability in the particular location;
- How the fireplace surround should be secured to different forms of wall construction and finish;
- The type of mechanical fittings to be used, positioning and fixing to the stone components and;
- The curing time before the fireplace can be used;
- Any additional information for the homeowner e.g how much weight may be placed upon the mantel.

Installers should ensure that they follow the manufacturer's and supplier's guidelines.

Planning Permission

Fitting altering or replacing an external flue or chimney is normally considered to be permitted development, not requiring planning permission, however, permission may be required in certain circumstances, where the flue terminates more than 1 metre above the highest point of the roof or in a conservation area if the flue or chimney is on an elevation fronting the highway, or on a listed buildings.

The above information relates to houses and not flats or maisonettes. The above information on planning permission is only general and you are advised to seek further information or clarification of whether permission is required by contacting the Development Management Section at your local authority.

Smoke Control Zones

Under Clean Air Acts some parts of the country have been designated as smoke control areas. This affects the type of appliance that you can install and the fuel that can be burned in it. The majority of the town of Darlington falls within one of 32 declared smoke control areas and solid fuel, wood burning and multi fuel stoves being fitted must be of an 'exempted type'. For more detailed information you should contact Environmental Health. In a smoke control area either an 'authorised fuel' must be used or solid fuel, wood burning and multi fuel stoves being fitted must be an 'exempt appliance'. Authorised fuels are fuels which are authorised under regulations made under the Clean Air Act and include inherently smokeless fuels such as anthracite together with specified brands of manufactured smokeless fuels. Exempt appliances have passed tests to confirm that they are capable of burning unauthorised or inherently smoky solid fuel without emitting smoke. Only fuel for which the appliances are designed should be used. Lists of authorised fuels and exempt appliances, together with further background information, can be found on the Defra website; www.smokecontrol.defra.gov.uk

Other Information

The following websites may be useful in obtaining further information about the installation of solid fuel stoves:

www.hetas.co.uk

www.planningportal.gov.uk

www.feta.co.uk/bfcma

www.smokecontrol.defra.gov.uk

You can also contact Building Control at:

Darlington Borough Council
Town Hall
Darlington
DL1 5QT

T : 01325 406214

Email: buildingcontrolenquiries@darlington.gov.uk

Our thanks to Hertfordshire Technical Forum who kindly allowed us to make of their material and research to produce this guidance note.